

.7x Reducer Lens – EdgeHD 9.25”

Instruction Manual – Model #94245

Your .7x Reducer Lens makes your EdgeHD 9.25” telescope one full F-Stop faster than at f/10. Photographically this will enable you to reduce your exposure times by one-half and still capture the same amount of light, while providing a 43% wider field of view.



| Telescope Model | f/2 Configuration | .7x Reducer Lens | Standard f/10 Configuration |
|-----------------|-------------------|-------------------|-----------------------------|
| 9.25” | 470 mm (18.5”) | 1,645 mm (64.75”) | 2,350 mm (92.5”) |

Focal lengths for the EdgeHD 9.25” in its native format (f/10), with the .7x reducer lens and with optional f/2 lens assembly.

Attaching the Reducer

1. Remove the visual back and adapter plate from the rear of the telescope.
2. The focal reducer threads directly onto the rear baffle lock nut (see Figure 1) of your EdgeHD telescope.
3. Attach your T-adaptor (#93646 or #93622, sold separately) onto the rear threads of the focal reducer.

Camera Spacing

Since optimal photographic back focus of 146 mm is the same with or without the focal reducer attached, the optional #93646 or #93622 T-Adapter can be used to attach the Nightscape CCD Camera, DSLR body or any other camera with 55 mm of back focus.

For best performance, it is highly recommended that you position your camera as close to the recommended optimal spacing as possible. It is best to maintain optimal spacing to within 1-3 mm depending on the size of your imaging sensor. As your imaging chip gets larger (farther off-axis), maintaining optimal spacing become more critical. Being inside of focus (too short) tends to affect the outermost edge of the field of view when using a relatively large sensor (17 mm or greater). Being outside of focus (too long) tends to produce elongated star images towards the edge and could run

the risk of running out of focus travel on your EdgeHD optical tube. In general it is better to be slightly inside of focus than outside of focus.

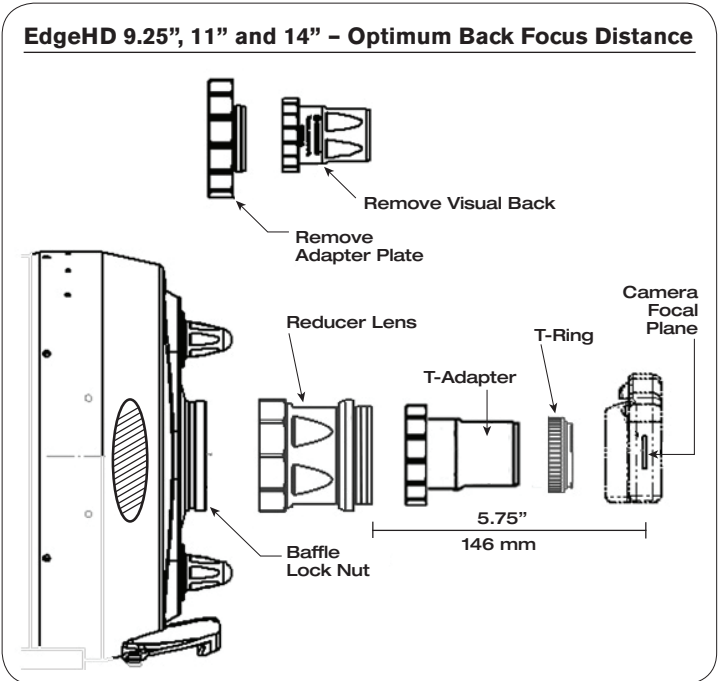

Figure 1 – Optimum Spacing for EdgeHD 9.25/11/14

Warranty: Two year limited warranty.
For complete warranty details contact Celestron or visit:

celestron.com

Celestron LLC • 2835 Columbia Street • Torrance, CA 90503

Phone: 310.328.9560 • Fax: 310.212.5835

©2018 Celestron • All rights reserved. #94245-INST 03-18